

actual size

SMD Quartz Crystal · HC-49/USM7

4 Pad Version · 12.9 x 4.73mm

- reflow soldering temperature: 260 °C max.
- package height 5 mm



General Data

type	HC-49/USM7	
frequency range	fund. AT-cut	3.27680 ~ 33.0 MHz (> 33.0 MHz, ask if available)
	3rd OT AT-cut	ask for availability
	fund. BT-cut	ask for availability
frequency tolerance at 25 °C	± 20 ppm ~ ± 50 ppm	
load capacitance C_L	7 pF ~ 32 pF or series / 30 pF standard	
shunt capacitance C_0	< 5 pF	
storage temperature	-40 °C ~ +125 °C	
drive level max.	100 uW (others recommended)	
aging	± 5 ppm max first year	

ESR (series resistance R_s)

frequency in MHz	vibration mode	ESR max. in Ω	ESR typ. in Ω
3.276 ~ 3.499	fund. AT	200	100
3.500 ~ 3.999	fund. AT	120	80
4.000 ~ 5.999	fund. AT	100	60
6.000 ~ 6.999	fund. AT	70	35
7.000 ~ 8.999	fund. AT	50	25
9.000 ~ 13.999	fund. AT	35	15
14.000 ~ 33.000	fund. AT	30	10
(33.000 ~ 40.000)	fund. AT	(30)	(10)
ask	3rd OT AT	(100)	(60)
ask	fund. BT	(50)	(20)

Frequency Stability vs. Temperature

		± 20 ppm	± 30 ppm	± 50 ppm	± 100 ppm	± 150 ppm	+10/-100 ppm
-10 °C ~ +60 °C	T1	D	○				○ BT-cut
-20 °C ~ +70 °C	STD	D	○	●			
-40 °C ~ +85 °C	T2		○	○	●		
-40 °C ~ +105 °C	T3			○	○		
-40 °C ~ +125 °C	T4					○	

● standard ○ available D ask, if available

Marking

frequency with load capacitance code
company code / date code / internal code

	Jan.	Febr.	Mar.	Apr.	May	June	July	Aug.	Sept.	Okt.	Nov.	Dec.
2011	2015	a	b	c	d	e	f	g	h	i	k	m
2012	2016	n	p	q	r	s	t	u	v	w	x	z
2013	2017	A	B	C	D	E	F	G	H	J	K	M
2014	2018	N	P	Q	R	S	T	U	V	W	X	Z

Dimensions

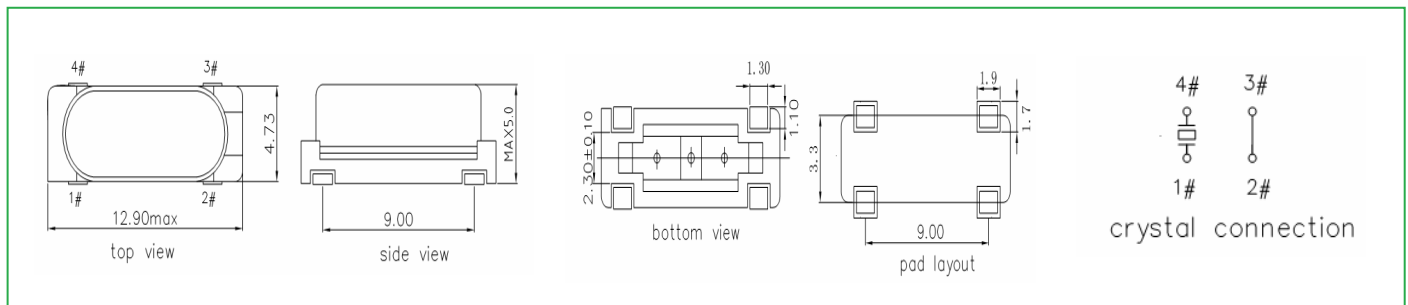

Taping Specification

